

Series T93 LA

**Folded shear beam load cell for
high accuracy weighing**
capacities 500 kg to 30,000 kg



stainless steel load sensor

unique folded shear beam design

fully welded construction sealed to IP 68

5 year warranty

simple low cost installation

integral lift off prevention

auto-phoretic toughened surface
(loading assembly only)

single point top loading allows for angular
misalignment

built-in thermal expansion capability

optional stainless steel loading assembly

This unique folded shear beam load cell is manufactured from high strength stainless steel and is sealed and fully welded for use in corrosive environments and washdown areas. Inherent in the design is resistance to side loading, as well as the additional benefits of a symmetrical bending moment and insensitivity to shifts in the load point. Maximum safety protection is given against lift-off by high wind or collision forces.

The T93 cell is designed for silo, hopper, tank and vessel, as well as platform weighing, and is very simple to install.

A comprehensive range of capacities is available in two body sizes. It is also available with intrinsically safe certification ATEX EEx ia IIC T6 to CENELEC Standards. Certified for use in both Gas and Dust Zones. The load cell and loading assembly are a fit-for-fit replacement for the existing T90 & T92 load cell ranges.



Thames Side - Maywood

...your specialist load cell partner

technical specification sheet

Series T93 LA

Standard Load Ranges	Load Cell Capacity		Units
	500, 1000, 2000, 3500, 5000 & 7500kg	10000, 15000, 20000 & 30000kg	
Rated Output	2	2	mV/V ± 0.25%
Combined Error	< ± 0.05	< ± 0.1	%*
Non-repeatability	< ± 0.025	< ± 0.03	%*
Creep (30 minutes)	< ± 0.05	< ± 0.05	%*
Temperature Effect on Zero Balance	< ± 0.0025	< ± 0.0025	%*/°C
Temperature Effect on Span	< ± 0.008	< ± 0.008	%*/°C
Compensated Temperature Range	-10 to +40	-10 to +40	°C
Operating Temperature Range	-40 to +80	-40 to +80	°C
Safe Overload	150	150	%*
Ultimate Overload	300	300	%*
Zero Balance	< ± 1	< ± 1	%*
Input Resistance	380	380	Ω ± 30
Output Resistance	350	350	Ω ± 1.5
Insulation Resistance	> 5000	> 5000	MΩ @ 100V
Recommended Supply Voltage	10	10	V
Maximum Supply Voltage	15	15	V

*With respect to rated output

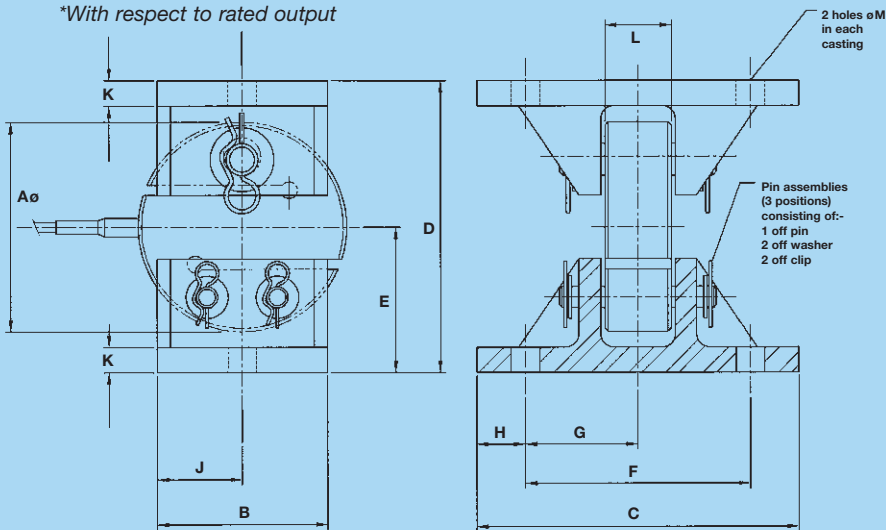

Capacity (kg)	A ø	B	C	D	E	F	G	H	J	K	L	M ø
500-7500	125	102	193	174	87	135	67.5	29	51	15	40	17.0
10000-30000	175	148	243	238	119	175	87.5	34	74	25	48	22.0

All dimensions in mm.

Note: Cell performance is characterised when tested in the specified loading assembly.

Electrical Connections

Via 4 core, 10m (20m for 10000kg model and up), 6mm dia., screened polyurethane cable.

Screen not connected electrically to load cell.

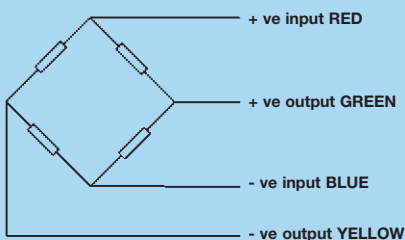

Shipping Weights: (kg)

Cell = 3.6 Cell = 9.3
LA 93 = 13.6 LA93 = 23.6

Construction

Load Cell manufactured from 17-4PH stainless steel heat treated to H900 condition - 1379N/mm² UTS.

Options

M16 conduit adaptor for connecting additional cable protection.

Stainless steel loading assembly.

Heavy duty earthing strap.

Our policy is one of continuous product enhancement. We therefore reserve the right to incorporate technical modifications without prior notification.

Distributed by

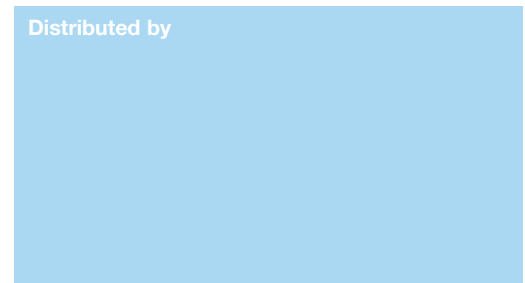

Thames Side - Maywood

Thames Side-Maywood Limited

2 Columbus Drive, Summit Avenue,
Southwood, Farnborough,
Hampshire GU14 0NZ

Tel: +44(0) 1252 555811

Fax: +44(0) 1252 375394

Email: sales@thames-side.co.uk

Web: www.thames-side-maywood.com

