

# Series 650

## S-beam load cells for commercial weighing

capacities 250kg to 5000kg



stainless steel load sensor

tension/compression

2.0 mV/V rationalised output

range of accessories available

fully welded construction sealed to IP 68

excellent long term stability

five year warranty

3000 divisions OIML R60 class C

A range of Stainless steel "S" beam load cells for commercial weighing to OIML R60 3000 divisions. Welded construction ensures total environmental sealing coupled with excellent long term stability.



***Thames Side - Maywood***

...your specialist load cell partner

# technical specification sheet

## Series 650

Standard Load Ranges	250, 500, 1000, 2000, 5000	kg
Full Load Output	2.0 (+/- 10%)	mV/V
Excitation Recommended	10	V
Excitation Maximum	15	V
Safe Service Load	150	%
Ultimate Load	200	%
Combined Error	<±0.017	%
Repeatability	<±0.015	%
Output at Zero load	<±2.0	%
Input Resistance	400±20	ohms
Output Resistance	350±3	ohms
Operational Temperature Range	-20 to +70	°C
Compensated Temperature Range	-10 to +40	°C
Temperature Effect on Zero	<±0.01	%/5°K
Temperature Effect on Sensitivity	<±0.006	%/5°K
Creep 30 mins (at 20°C)	<±0.016	%
Environmental. Protection	IP68	
Cable Length	5	m
Insulation	>5000	M ohms

All percentages are related to Full Rated Load

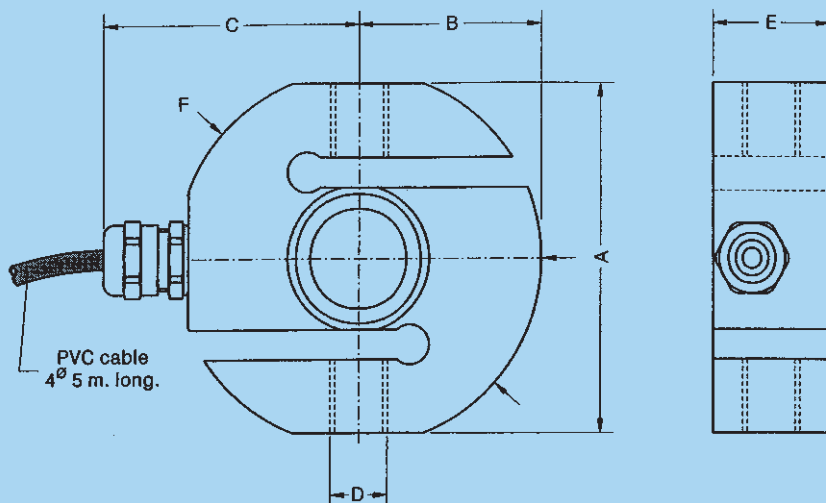

Nominal Load	A	B	C	D	E	Fø	Shipping Weight kg
250-500kg	70	37.5	50	M12x1.75	24.5	75	1
1-2te	95	50	60	M20x1.5	30	100	2
5te	120	62.5	72.5	M24x2	40	125	4

Dimensions in mm.

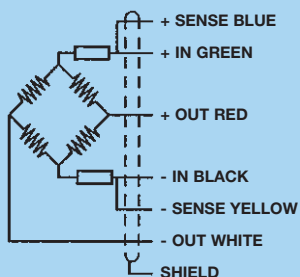

**SENSES:**  
2 additional wires to maintain a constant voltage supply at the load cell when used with appropriate instrumentation. Use specially when long wires and wide temperature range.

**Electrical Connections**  
Via 6 core, 4mm diameter screened pvc cable.

**Construction**  
17-4PH stainless steel. Fully welded.

**Screen not connected to load cell body.**

Our policy is one of continuous product enhancement. We therefore reserve the right to incorporate technical modifications without prior notification.

Distributed by

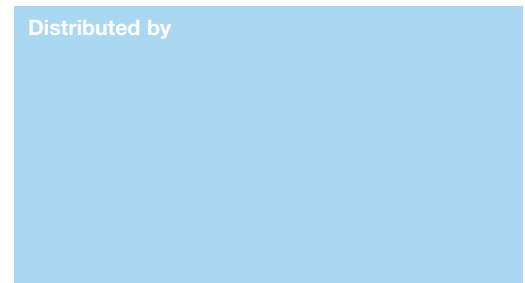

### Thames Side - Maywood

**Thames Side-Maywood Limited**  
2 Columbus Drive, Summit Avenue,  
Southwood, Farnborough,  
Hampshire GU14 0NZ

Tel: +44(0) 1252 555811

Fax: +44(0) 1252 375394

Email: sales@thames-side.co.uk

Web: www.thames-side-maywood.com

