

Series 350i

Shear beam load cells for industrial weighing

capacities 300kg to 5,000kg

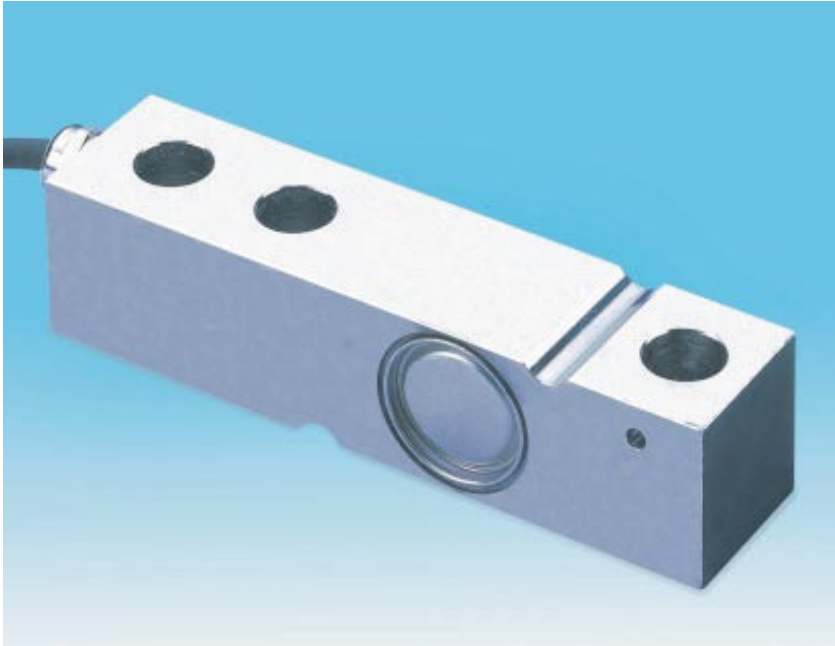

Stainless steel load sensor

5 year warranty

Fully welded and hermetically sealed to IP68

Industry standard configuration

Corrosion resistant

Optional load feet, mounting plates and load buttons

3000 divisions OIML R60 Class C

Optional anti-vibration loading assembly

Simple low cost installation

Optional Levermount® loading assembly

This cell is typically used in weigh platforms, tanks and vessel weighing, bag filling machines and conveyors, and is approved to OIML R60 3000 divisions.

Fully welded construction ensures total environmental sealing coupled with excellent long term stability. Available with intrinsically safe certification ATEX EEx ia IIC T6 for use in both Gas and Dust zones. High temperature option for operation up to 150 °C

technical specification sheet

Series 350i - Stainless steel, fully welded & hermetically sealed

	Load Cell Capacities	Units
Standard Load Ranges	300, 500, 1000,	kg
	2000, 3000, 5000	kg
Rated Output	2	mV/V \pm 0.1%
Accuracy Class	3000	n.OIML
Combined Error	$<\pm 0.017$	%*
Non-repeatability	$<\pm 0.015$	%*
Creep (30 minutes)	$<\pm 0.016$	%*
Temperature Effect on Zero Balance	$<\pm 0.01$	%*/ $^{\circ}$ C
Temperature Effect on Span	$<\pm 0.006$	%*/ $^{\circ}$ C
Compensated Temperature Range	-10 to +40	$^{\circ}$ C
Operating Temperature Range	-20 to +70	$^{\circ}$ C
Safe Overload	150	%*
Ultimate Overload	200	%*
Zero Balance	$<\pm 2$	%*
Input Resistance	400	$\Omega \pm 30$
Output Resistance	350	$\Omega \pm 1.5$
Insulation Resistance	>5000	M Ω @ 100v
Recommended Supply Voltage	10	V
Maximum Supply Voltage	15	V
Environmental Protection	IP68	-

*With respect to rated output

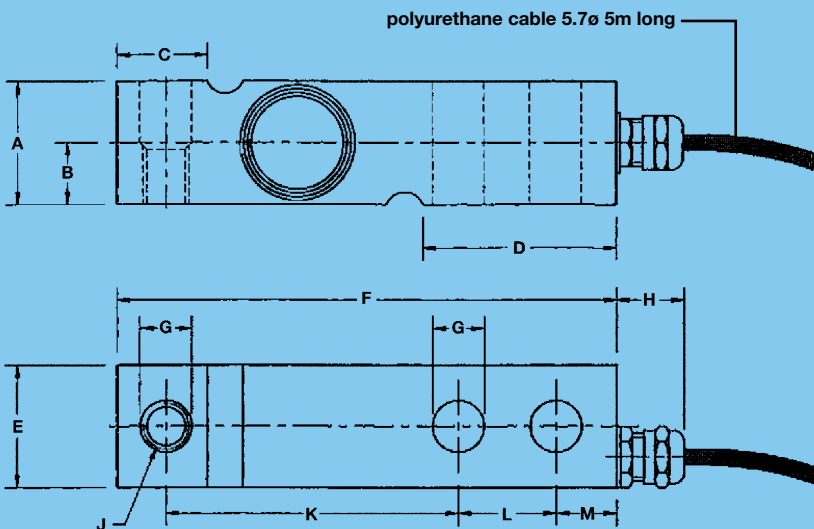

Range (kg)	A	B	C	D	E	F	Gø	H	J	K	L	M	Weight
300 - 2000	31.5	15	24.6	51.6	31.5	130	13.5	18	M12	76.2	25.4	15.8	0.9kg
3000 - 5000	48	-	37	70	38.5	171.5	20.5	18	-	95.2	38.1	19	2.2kg

All dimensions in mm.

Electrical Connections Series 350i

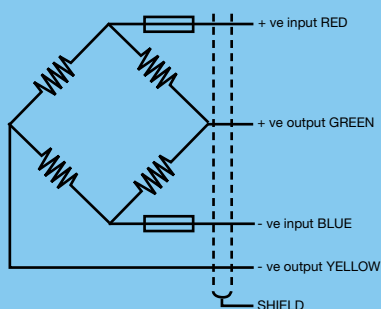

Screen not connected to load cell body

Load Foot for 350



LeverMount



AV Mount



Our policy is one of continuous product enhancement. We therefore reserve the right to incorporate technical modifications without prior notification.

Distributed by



Thames Side Sensors Ltd

Unit 10, io Trade Centre, Deacon Way,
Reading, Berkshire RG30 6AZ
tel: +44 (0) 118 941 1387 fax: +44 (0) 118 941 2004
e-mail: sales@thames-side.co.uk
web: www.thames-side.com